

Low Cost, Compact Data Acquisition Kit

Convenient USB or Ethernet Interface

Four $\pm 10\text{V}$ or $\pm 64\text{V}$ Analog Fixed Differential Inputs

Four General Purpose Digital Inputs

Supports Sample Throughput Rates up to 14,400 Hz (USB) or 4,800 Hz (Ethernet)

12-bit Resolution

DI-158 products break new ground in price and performance, offering advanced features and options usually reserved for more expensive instruments. A channel scan list, high sample throughput rates, and an advanced computer interface are just some of the features combined to produce a robust instrument that can be applied to nearly any data acquisition situation where low and high level signals need to be acquired to a PC.

Options include a USB or Ethernet interface and high level gain/high full scale range. USB devices are powered through the interface while Ethernet devices require a provided AC adapter. Gain range per channel options are 1, 2, 4, and 8 with a full scale range of ± 10 volts or 1, 2, 4, 8, 16, 32, 64, 128, 256, and 512 with a full scale range of ± 64 volts.



Shown: A DI-158 with the USB interface option

Features

Easy to Connect and Use

USB option allows the DI-158 to connect to any local laptop or desktop PC. Power is derived from the PC through the USB interface so no external power is required. The Ethernet option allows the DI-158 to be connected to a remote PC over a network.

Two, built-in, 8 position screw terminal connectors allow easy and secure access to all DI-158 signal I/O connections without the need for extra options.

High Resolution

12-bit measurement resolution provides a responsive instrument capable of registering changes as small as one part in $2,048 \pm 0.05\%$ of the full scale measurement range.

Wide Sample Throughput Range

Throughput ranges from sub-Hertz to up to 14,400 Hertz allow the DI-158 to connect to a wide range of both static and dynamic signals.

Compact

Small size— $66\text{D} \times 66\text{W} \times 28\text{H}$ mm ($2.6\text{D} \times 2.6\text{W} \times 1.1\text{H}$ inches)—allows the DI-158 to fit comfortably in crowded instrumentation cabinets, desktops, and other tight locations.

Built-In Channel-Gain Scan List

The Built-in channel-gain scan list eliminates unpredictable channel skews and allows channels to be selectively enabled or disabled to match your application. It also allows channel gain to be dynamically selected per channel during scanning to precisely match signal requirements on a channel by channel basis.

Built-In, Bidirectional Port

Built-in bidirectional port allows programmable discrete inputs and outputs for control.

Free Data Acquisition Software

Our WINDAQ/Lite data acquisition software offers real-time display and disk-streaming for the Windows environment. The real-time display can operate in a smooth scroll or triggered sweep mode of operation, and can be scaled into any unit of measure. Event markers with comments allow you to annotate your data acquisition session as you're recording to disk.

Raise your productivity to new heights with WINDAQ's unique multitasking feature. Record waveform data to disk in the background while running any combination of programs in the foreground — even WINDAQ Playback software to review and analyze the waveform data as it's being stored!

Specifications

Analog Inputs

Number of Channels: 4
Channel Configuration: Fixed Differential

Measurement range (Full Scale), Accuracy, and Resolution

	Gain	Range	Accuracy	Resolution
DI-158U:	1	±10V	±0.1% of FSR	±4.88mV
	2	±5V	±0.1% of FSR	±2.44mV
	4	±2.5V	±0.1% of FSR	±1.22mV
	8	±1.25V	±0.1% of FSR	±0.61mV
DI-158UP and DI-158EP: (models with programmable high gain option)	1	±64V	±0.1% of FSR	±31.3mV
	2	±32V	±0.1% of FSR	±15.6mV
	4	±16V	±0.1% of FSR	±7.81mV
	8	±8V	±0.1% of FSR	±3.9mV
	16	±4V	±0.1% of FSR	±1.95mV
	32	±2V	±0.1% of FSR	±976µV
	64	±1V	±0.1% of FSR	±488µV
	128	±0.5V	±0.1% of FSR	±244µV
	256	±0.25V	±0.1% of FSR	±122µV
	512	±0.125V	±0.1% of FSR	±61µV

Input Impedance: 500KΩ either input to ground, 1MΩ differential
Input bias current: 10µA for a 10V input, single channel
Max. normal mode voltage: 200V peak
Max. common mode voltage: 60V peak
Common mode rejection: 60db @ Gain=1; 1KΩ unbalance
Channel-to-channel crosstalk rejection: 100db
Gain temperature coefficient: 100ppm/°C
Offset temperature coefficient: 100µV/°C

A/D Characteristics

Type: Successive approximation
Resolution: 12-bit
Monotonicity: ±2 LSB
Conversion Time: 71.4µs

Calibration

Calibration cycle: One year
Calibration method: Digital calibration with scale and offset constant per channel and gain range.

USB Interface

Connector: USB
Max. data transfer rate: 14,400 samples per second

Analog Outputs

Number of channels: 2
Resolution: 12 bits
Integral Nonlinearity: ±2 LSB
Output Noise: 250µVrms
Output Current: ±300µA
Output short circuit current: 15mA
Voltage output slew rate: Load = 40pF: 0.44 V/µs
Output voltage swing: 0V to 1.25V
Startup time: 10µs

Digital I/O

Channels: 4 bi-directional ports
Output voltage levels: Min. "1" 3V @ 2.5mA sourcing
 Max. "0" 0.4V @ 2.5mA sinking
Output current: Max. source, -2.5 mA
 Max. sink, 2.5mA
Input voltage levels: Min. required "1" 2V
 Max allowed "0" 0.8V

Ethernet Interface

Type: 10/100Base-T
Connector: RJ-45
Protocol: TCP/IP
Max. data transfer rate: 4,800 samples per second

General

Input connectors: Two, 8 position terminal blocks
Operating Environment: 0°C to 70°C
Enclosure: Molded ABS plastic
Dimensions: 2.6L × 2.6W × 1.1D inches
 66L × 66W × 28D mm.
Weight: 3 oz. (85 gr.)
Power Requirements
 USB Models: No external power required. Power derived from communications cable.
 Ethernet Model: 5V DC @ 300mA

Scanning Characteristics

Max. throughput sample rate: USB: 14,400 Hz Ethernet: 4,800 Hz
Min. throughput sample rate: 0.0137334 Hz
Max. scan list size: 6 entries
Sample buffer size: 2kb

DI-158 Analog Inputs (Typical)

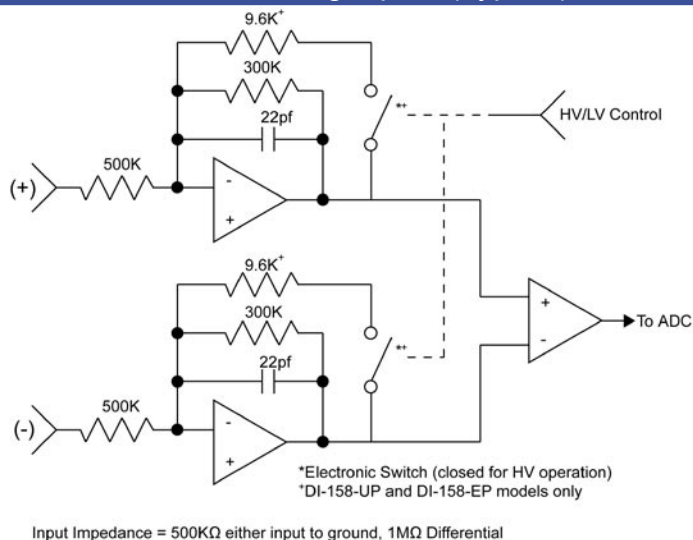

Ordering Guide

Description	Order Number
DI-158U Starter Kit DI-158 with USB interface.	DI-158U
DI-158UP Starter Kit DI-158 with USB Interface and high programmable gain/voltage range.	DI-158UP
DI-158E Starter Kit DI-158 with Ethernet Interface and high programmable gain./voltage range	DI-158EP

Data Acquisition Product Links

(click on text to jump to page)

[Data Acquisition](#) | [Data Logger](#) | [Chart Recorder](#) | [Thermocouple](#) | [Oscilloscope](#)



241 Springside Drive
 Akron, Ohio 44333
 Phone: 330-668-1444
 Fax: 330-666-5434